

SUPERFORMER SF1

AUTOMATIC CASE ERECTOR



The Superformer SF1 erects RSC cases, folds the bottom flaps and closes them with tape. Unique features of this machine include stainless steel exterior finish, automatic case squaring system, easy size change, tape and case monitoring.



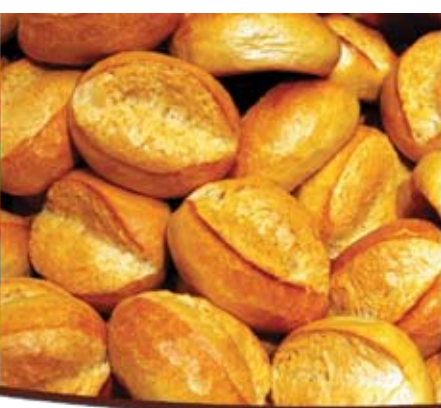

TECHNICAL SPECIFICATIONS SUPERFORMER SF1:

Case range:	Superformer SF1S 8.00" x 6.00" x 3.00" (L x W x H) min. 20.00" x 16.00" x 20.00" (L x W x H) max.
	Superformer SF1 8.00" x 8.00" x 6.00" (L x W x H) min. 24.00" x 20.00" x 24.00" (L x W x H) max.
	Superformer SF1L 14.00" x 10.00" x 6.00" (L x W x H) min. 31.50" x 20.00" x 24.00" (L x W x H) max.
Speed:	Superformer SF1S Up to 15 cases per min. (Servo up to 20 cases per min.)
	Superformer SF1 Up to 13 cases per min. (Servo up to 20 cases per min.)
	Superformer SF1L Up to 9 cases per min. (Servo up to 14 cases per min.)
Taping heads:	OK 55 high quality taping head with open tape feed path, suitable for 2" wide tape (max.) and 14" diameter rolls.
Case magazine:	Horizontal, belt driven, indexing magazine, length 40".
Electric:	480V, 3 Phase, 60Hz standard. Other voltages to requirement.
Pneumatic:	80-100 psi, 1/2" supply.
Controls:	PLC controls with operator fault finding display. Signals for low tape, no tape, tape not applied, low case magazine, and empty case magazine.
Finish:	Stainless steel frame, covers and electrical enclosure, plated and painted interior.
Machine handling:	Right to left or left to right to requirement.

FEATURES

Quick and easy size change.	Increased production efficiency and flexibility.
Automatic case squaring system.	Consistency for automatic lines and enhanced cosmetics.
Tape and case monitoring package.	Operator friendly and reliability.
Single frame, in line design.	Ease of setup, training and operation.
Stainless steel exterior finish.	Clean and durable finish, preferred in food and other industries.

BENEFITS

SUPERFORMER DRAWING:

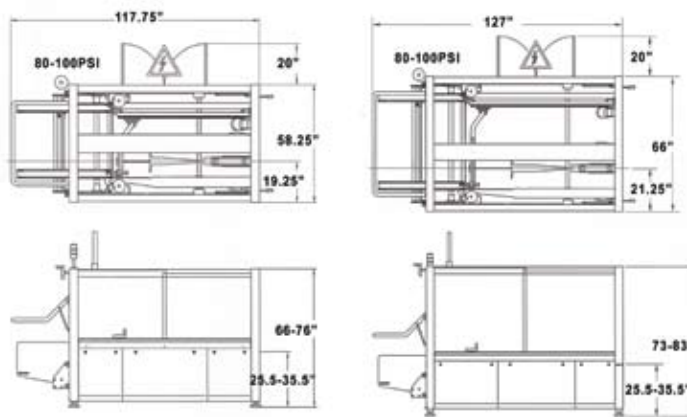

Superformer SF1S

Superformer SF1

SUPERFORMER SF1 OPTIONS:

- Smaller case sizes.
- Touch screen display unit.
- All stainless steel.
- Superformer SF1 Servo Higher Speed Case Erectors.
- OK 75 taping head for 3" wide tape.
- Case magazine 60" long.
- Superformer SFHM Hot-Melt Case Erectors.



Our machines can be used to pack almost any product:

Fruits, nuts, vegetables, scallions, meats, poultry, seafood, cereals, crackers, rice, pasta, tortillas, snack food, sugar, cutlery, chocolate, herbs, spices, seed, coffee, tea, bakery goods, gypsum, flatbread, caps, closures, plastics, screws, medical devices, powders, pharmaceutical devices.



OK International Corporation
73 Bartlett Street
Marlborough, MA 01752
USA
Phone: 1-508-303-8286
Fax: 1-508-303-8207
sales@okcorp.com