

SUPERFORMER SF1

AUTOMATIC CASE ERECTOR



The Superformer SF1 erects RSC cases, folds the bottom flaps and closes them with tape. Unique features of this machine include stainless steel exterior finish, automatic case squaring system, easy size change, tape and case monitoring.





TECHNICAL SPECIFICATIONS SUPERFORMER SF1:

Case range:	Superformer SF1S 200mm x 150mm x 75mm (L x W x H) min. 500mm x 400mm x 500mm (L x W x H) max.
	Superformer SF1 200mm x 200mm x 150mm (L x W x H) min. 600mm x 500mm x 600mm (L x W x H) max.
	Superformer SF1L 200mm x 200mm x 150mm (L x W x H) min. 800mm x 500mm x 700mm (L x W x H) max.
Speed:	Superformer SF1S Up to 16 cases per min. (Servo up to 20 cases per min.)
	Superformer SF1 Up to 13 cases per min.
	Superformer SF1L Up to 9 cases per min.
Taping heads:	OK 55 high quality taping head with open tape feed path, suitable for 50mm wide tape (max.) and 350 mm diameter rolls.
Case magazine:	Horizontal, belt driven, indexing magazine, length 1000mm.
Electric:	400V, 3 Phase, 50Hz standard. Other voltages to requirement.
Pneumatic:	6 - 8 bar, 1/2" supply.
Controls:	PLC controls with operator fault finding display. Signals for low tape, no tape, tape not applied, low case magazine, and empty case magazine.
Finish:	Stainless steel frame, covers and electrical enclosure, plated and painted interior.
Machine handling:	Right to left or left to right to requirement.

FEATURES

Quick and easy size change.	Increased production efficiency and flexibility.
Automatic case squaring system.	Consistency for automatic lines and enhanced cosmetics.
Tape and case monitoring package.	Operator friendly and reliability.
Single frame, in line design.	Ease of setup, training and operation.
Stainless steel exterior finish.	Clean and durable finish, preferred in food and other industries.

BENEFITS

SUPERFORMER DRAWING:

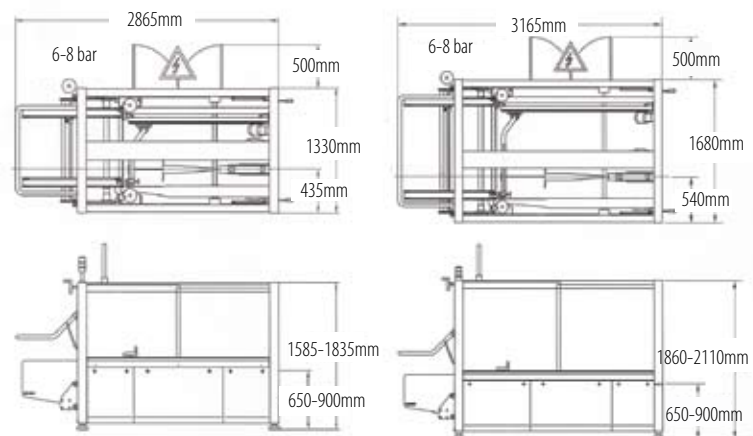

Superformer SF1M

Superformer SF1

Superformer SF1

SUPERFORMER SF1 OPTIONS:

- Smaller case sizes.
- Powder coated finish.
- All stainless steel.
- Superformer SF2 High Speed Case Erectors.
- OK 75 taping head for 75mm wide tape.
- Case magazine 1500mm long.
- Superformer SFHM Hot-Melt Case Erectors.



Our machines can be used to pack almost any product:

Fruits, nuts, vegetables, scallions, meats, poultry, seafood, cereals, crackers, rice, pasta, tortillas, snack food, sugar, cutlery, chocolate, herbs, spices, seed, coffee, tea, bakery goods, gypsum, flatbread, caps, closures, plastics, screws, medical devices, powders, pharmaceutical devices.

