

SUPERFORMER SF2

HIGH SPEED AUTOMATIC CASE ERECTOR



The Superformer SF2 Automatic Case Erectors are high speed double arm machines. All the great performance and features of the Superformer Series in a fast and reliable platform.



OKCORP.COM



TECHNICAL SPECIFICATIONS SUPERFORMER SF2:

Case range:	Superformer SF2M 200mm x 150mm x 75mm (L x W x H) min. 400mm x 350mm x 400mm (L x W x H) max.
	Superformer SF2 200mm x 200mm x 150mm (L x W x H) min. 700mm x 450mm x 500mm (L x W x H) max.
Speed:	Superformer SF2M Up to 25 cases per min. Superformer SF2 Up to 20 cases per min.
Taping heads:	OK 55 high quality taping head with open tape feed path, suitable for 50mm wide tape (max.) and 350mm diameter rolls.
Case magazine:	Horizontal, belt driven, indexing magazine, length 1000mm.
Electric:	400V, 3 Ph, 50 Hz. Other voltages to requirement.
Pneumatic:	6 - 8 bar, 1/2" supply.
Controls:	PLC controls with operator fault finding display. Signals for low tape, no tape, tape not applied, low case magazine and empty case magazine.
Finish:	Stainless steel frame, covers and electrical enclosure, plated and painted interior.
Machine handling:	Right to left or left to right to requirement.

FEATURES

Quick and easy size change.	Increased production efficiency and flexibility.
Automatic case squaring system.	Consistency for automatic lines and enhanced cosmetics.
Tape and case monitoring package.	Operator friendly and reliability.
Single frame, in line design.	Ease of setup, training and operation.
Stainless steel exterior finish.	Clean and durable finish, preferred in food and other industries.

BENEFITS

SUPERFORMER SF2 DRAWINGS:

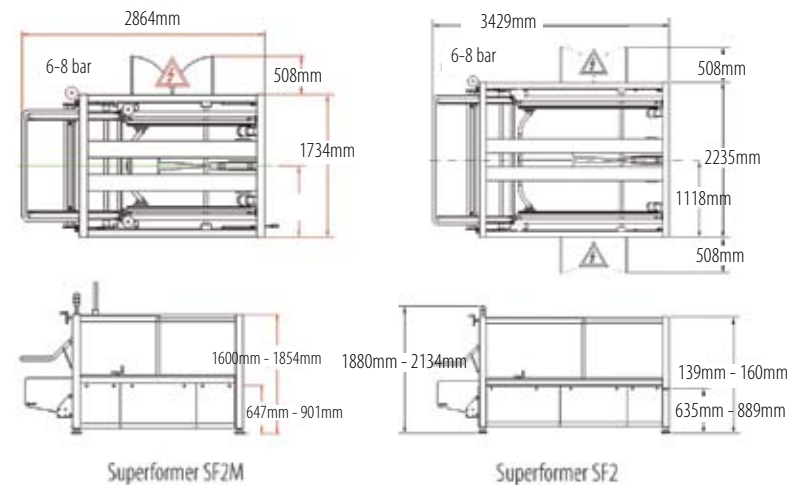

SUPERFORMER SF2 OPTIONS:

- Smaller case sizes.
- Powder coated finish.
- All stainless steel.
- Superformer SF1 Standard Speed Case Erectors.
- OK 75 taping head for 75mm wide tape.
- Case magazine 1500mm long.
- Superformer SFHM Hot-Melt Case Erectors.



Our machines can be used to pack almost any product:

Fruits, nuts, vegetables, scallions, meats, poultry, seafood, cereals, crackers, rice, pasta, tortillas, snack food, sugar, cutlery, chocolate, herbs, spices, seed, coffee, tea, bakery goods, gypsum, flatbread, caps, closures, plastics, screws, medical devices, powders, pharmaceutical devices.

