

M-800 SERIES

Modular Rope Belt Conveyor



CONVEYORS SYSTEM

The new M-800 Series is a modular, stainless steel, powered case conveyor system for medium duty applications. An economic, custom system can be created with straight, inclined, declined and corner sections, with the drive slaved off a main section. The M-800 series is a clean and attractive alternative for powered roller or belt conveyor systems.

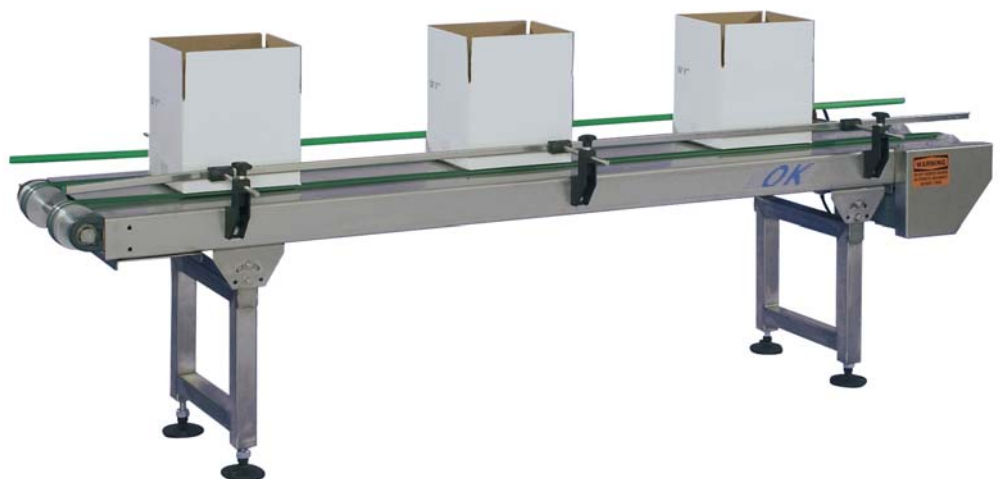

M-800 Series

Modular Rope Belt Conveyor System

Features:

- Modular design
- Stainless steel finish
- Simple rope-belt design
- Cost effective

Benefits:

- Create a custom system with standard sections to suit your requirement
- Clean and durable, maintains hygiene
- Low maintenance and easy belt change
- Quick return of investment

Technical Specifications:

Lengths:	8' long modules or to requirement
Frame width:	18" or to requirement
Belt Speed:	40 ft./min., variable speed or fixed speeds to requirement
Power requirements:	110 VAC, 1 Ph, 60Hz, 4 Amp or to requirement
Pneumatic:	1/4" supply, 80 PSI, only required for optional items
Case weight range:	Up to 40 lbs.
Conveyor motors:	1/4 HP (one motor gearbox every 16 - 80 ft. depending on applications)
Conveyor finish:	Stainless steel
Table height:	To requirement
Handing:	Right to Left or Left to Right to requirement
Side rails:	Standard
Leveling feet:	Standard

Conveyor Dimensions:

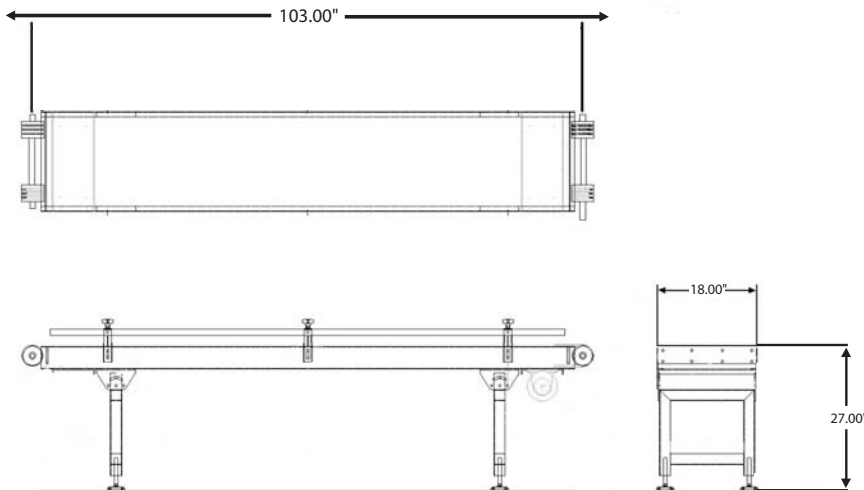

CONVEYOR SYSTEM

M-800 Series Options

Inclined modules

Declined modules

Corners

Case stops and clamps for case indexing on demand

Case lift and transfer sections

Casters

Adjustable Legs



O/K International Corporation

73 Bartlett Street
Marlborough, MA 01752 USA
Tel. 508.303.8286
Fax 508.303.8207
sales@okcorp.com
www.okcorp.com

WORLDWIDE LOCATIONS:

O/K Durable Packaging
Chicago, IL USA

O/K International (Europe)
Stanton, England

O/K Packaging Systems BV
Lisse, The Netherlands